

PIERŚCIEŃ ODCIĄŻAJĄCE DUKO RING TYP PO

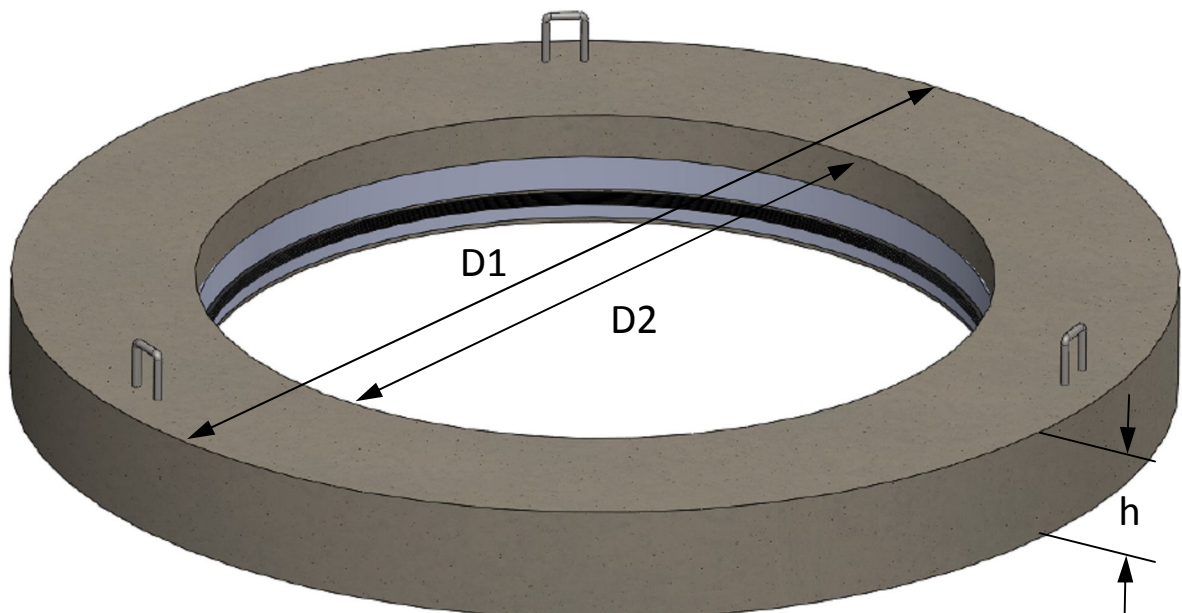

Typ	D ¹	D1	D2	h	ciężar
	mm	mm	mm	mm	kG
PO-600	600	1400	617	240	757
PO-800	800	1600	821	240	898
PO-900	900	1700	923	240	970
PO-1000	1000	1800	1025	240	1043
PO-1100	1100	1900	1127	240	1117
PO-1200	1200	2000	1229	240	1172
PO-1400	1400	2200	1433	240	1275
PO-1500	1500	2300	1535	240	1342
PO-1600	1600	2400	1637	240	1407
PO-1800	1800	2600	1841	240	1538
PO-2000	2000	2800	2045	240	1668
PO-2200	2200	3000	2249	240	1795
PO-2400	2400	3200	2453	240	1921
PO-2600	2600	3500	2657	240	2355
PO-2800	2800	3700	2861	240	2495
PO-3000	3000	3900	3065	240	2633

¹ D – średnica nominalna rury studziennej GRP Flowtite